



# VOLVO GENUINE CHARGE AIR COOLERS

Charge Air Cooler Sales Tips

## WHAT IS A CAC?

The charge air cooler (CAC), also known as the intercooler, chills the forced air after passing through the turbocharger, but before hitting the engine. Passing a compressed and heated intake “charge” through an intercooler reduces its temperature and pressure.

## THE PURE MACK VALUE

A Volvo Genuine Charge Air Cooler creates denser air combustion, allowing for more effective engine output and better fuel economy, eliminating downtime and lost revenue.

## WHERE TO BUY

Available through your nearest Volvo Dealership.

22769526 available through the PDC.

DOAM5706503 available through the VDSP program (instructions available through VDSP Part Lookup on Compass).

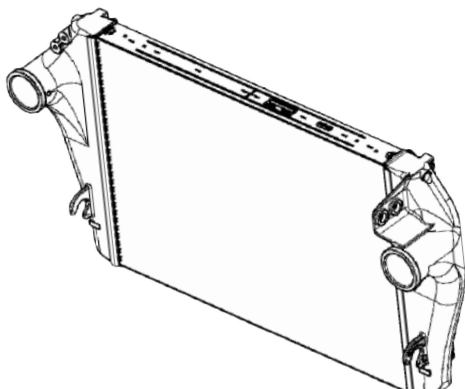

## FEATURES AND BENEFITS

- OE spec provides precise performances synchronized with the cooling package and engine at large
- Engineered to reduce temperature relative to pressure loss for maximum combustion for best fuel economy
- Provides more fuel/air burn per engine cycle, increasing engine output and performance
- Unique fin design helps retain and distribute heat more effectively
- Specially designed core cover allows for thermal expansion within a set tolerance, plus an added breakaway feature protects core components
- Proprietary inverted ferrule design improves strength and durability

## ADVANTAGES

It is important to note that replacing the CAC, or any component of the cooling package, with a competitor’s offering will not ensure better engine performance. The performance of the cooling package is a sum of all constituent parts performing at the exact specifications intended for the truck. Staying Pure Mack will help ensure maximum performance and uptime to our customers for the miles ahead.

## APPLICATIONS

Fits on all VNL and VNR models

## PART NUMBERS

22769526 – 29 Row

BOAM5706503 – 29 Row – Vendor Direct Ship Program



# VOLVO GENUINE CHARGE AIR COOLERS

## 7 Signs of a Leaking Charge Air Cooler

---



The charge air cooler (CAC) plays an important role in your truck's cooling system, making sure the compressed air from the turbocharger is adequately cooled before it flows into the engine.

But a leaking CAC can disrupt the cooling process, leading to higher underhood temperatures and significant problems for your engine.

### 7 SIGNS OF A LEAKING CAC:

1. Decreased fuel economy
2. Low engine power
3. Excessive soot in the oil
4. More frequent DPF regenerations
5. Premature piston, ring and valve failure
6. Elevated coolant temperatures
7. Costly repairs, including turbocharger and exhaust manifold failures

The best way to diagnose an underperforming CAC – and avoid expensive downtime and related component failure – is through a leak-down pressure test. In just minutes, you or a service technician can measure the leak-down rate of the CAC. If it exceeds your engine manufacturer's specific recommendations, it's time to consider replacing your CAC.

**VOLVO**

Volvo Trucks

[www.volvotrucks.us](http://www.volvotrucks.us) | [www.volvotrucks.ca](http://www.volvotrucks.ca)

©2019 Volvo Truck Group North America, LLC

PV960-V-092719